



End mill holders DIN 6359 for end mills DIN 1835-E

(DIN 69893-1 | HSK-A)

Porte-fraises DIN 6359 pour queues cylindriques DIN 1835-E

**Verwendung:**

Zum Spannen von zylindrischen Werkzeugschäften mit geneigter Spannfläche nach DIN 1835 Form E (Whistle Notch).

Application:

For mounting straight-shank tools and inclined flat according to DIN 1835 form E (Whistle Notch).

Application:

Pour le serrage d'outils avec queue cylindrique et avec méplat incliné suivant DIN 1835 forme E (Whistle Notch).

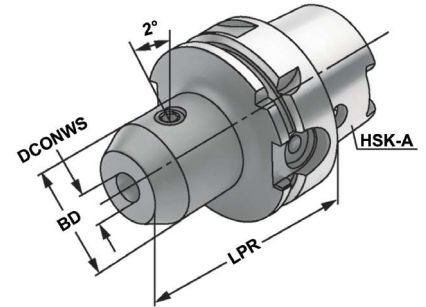

5

Bestell-Nr. Order no. Référence	HSK	DCONWS	TDCON	LPR	BD
A32.05.06	HSK-A 32	6	H4	80	25
A32.05.08	HSK-A 32	8	H4	80	28
A32.05.10	HSK-A 32	10	H4	80	32
A32.05.12	HSK-A 32	12	H4	80	32
A32.05.14	HSK-A 32	14	H4	80	32
A32.05.16	HSK-A 32	16	H4	90	32
A32.05.18	HSK-A 32	18	H4	90	34
A32.05.20	HSK-A 32	20	H4	90	34
A40.05.06	HSK-A 40	6	H4	80	25
A40.05.08	HSK-A 40	8	H4	80	28
A40.05.10	HSK-A 40	10	H4	80	35
A40.05.12	HSK-A 40	12	H4	90	42
A40.05.14	HSK-A 40	14	H4	90	44
A40.05.16	HSK-A 40	16	H4	90	48
A40.05.18	HSK-A 40	18	H4	90	40
A40.05.20	HSK-A 40	20	H4	90	40
A40.05.25	HSK-A 40	25	H4	100	46
A40.05.32	HSK-A 40	32	H4	110	54
A50.05.06	HSK-A 50	6	H4	80	25
A50.05.08	HSK-A 50	8	H4	80	28
A50.05.10	HSK-A 50	10	H4	80	35
A50.05.12	HSK-A 50	12	H4	90	42
A50.05.14	HSK-A 50	14	H4	90	44
A50.05.16	HSK-A 50	16	H4	90	48
A50.05.18	HSK-A 50	18	H4	90	50
A50.05.20	HSK-A 50	20	H4	100	52
A50.05.25	HSK-A 50	25	H4	110	60
A50.05.32	HSK-A 50	32	H4	110	60

Hinweis: Ab DCONWS = 25 mit zwei Spannschrauben
Note: From DCONWS = 25 on two clamping screws
Observation: A partir de DCONWS = 25 avec deux vis de serrage

Lieferumfang: Mit Spannschraube und axialer Verstellerschraube
Delivery: With clamping screw and axial adjustment bolt
Livraison: Avec vis de serrage et vis de butée axiale



End mill holders DIN 6359 for end mills DIN 1835-E

(DIN 69893-1 | HSK-A)

Porte-fraises DIN 6359 pour queues cylindriques DIN 1835-E

**Verwendung:**

Zum Spannen von zylindrischen Werkzeugschäften mit geneigter Spannfläche nach DIN 1835 Form E (Whistle Notch).

Application:

For mounting straight-shank tools and inclined flat according to DIN 1835 form E (Whistle Notch).

Application:

Pour le serrage d'outils avec queue cylindrique et avec méplat incliné suivant DIN 1835 forme E (Whistle Notch).

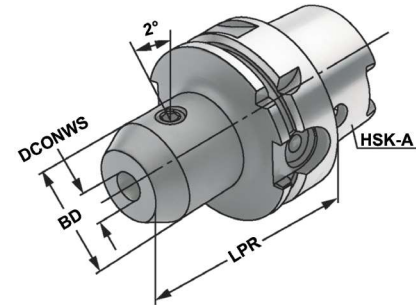

Bestell-Nr. Order no. Référence	HSK	DCONWS	TDCON	LPR	BD
A63.05.06	HSK-A 63	6	H4	80	25
A63.05.08	HSK-A 63	8	H4	80	28
A63.05.10	HSK-A 63	10	H4	80	35
A63.05.12	HSK-A 63	12	H4	90	42
A63.05.14	HSK-A 63	14	H4	90	44
A63.05.16	HSK-A 63	16	H4	100	48
A63.05.18	HSK-A 63	18	H4	100	50
A63.05.20	HSK-A 63	20	H4	100	52
A63.05.25	HSK-A 63	25	H4	110	65
A63.05.32	HSK-A 63	32	H4	110	72
A80.05.06	HSK-A 80	6	H4	90	25
A80.05.08	HSK-A 80	8	H4	90	28
A80.05.10	HSK-A 80	10	H4	90	35
A80.05.12	HSK-A 80	12	H4	100	42
A80.05.14	HSK-A 80	14	H4	100	44
A80.05.16	HSK-A 80	16	H4	100	48
A80.05.18	HSK-A 80	18	H4	100	50
A80.05.20	HSK-A 80	20	H4	110	52
A80.05.25	HSK-A 80	25	H4	110	65
A80.05.32	HSK-A 80	32	H4	120	72
A100.05.06	HSK-A 100	6	H4	90	25
A100.05.08	HSK-A 100	8	H4	90	28
A100.05.10	HSK-A 100	10	H4	90	35
A100.05.12	HSK-A 100	12	H4	100	42
A100.05.14	HSK-A 100	14	H4	100	44
A100.05.16	HSK-A 100	16	H4	100	48
A100.05.18	HSK-A 100	18	H4	100	50
A100.05.20	HSK-A 100	20	H4	110	52
A100.05.25	HSK-A 100	25	H4	120	65
A100.05.32	HSK-A 100	32	H4	120	72
A100.05.40	HSK-A 100	40	H4	120	80

Hinweis: Ab DCONWS = 25 mit zwei Spannschrauben
Note: From DCONWS = 25 on two clamping screws
Observation: A partir de DCONWS = 25 avec deux vis de serrage

Lieferumfang: Mit Spannschraube und axialer Verstelle schraube
Delivery: With clamping screw and axial adjustment bolt
Livraison: Avec vis de serrage et vis de butée axiale

